

Service guide

## PAH, PAHT, PAHT G pumps

PAH 10-12.5, PAHT 10-12.5 and  
PAHT G 10-12.5  
Disassembling and assembling



Table of Contents

1.	Disassembling the pump .....	3
2.	Inspection .....	7
2.1.	Port plate and valve plate .....	7
2.2.	Pistons .....	7
2.3.	Cylinder barrel .....	8
2.4.	Housing .....	8
2.5.	Swash plate .....	8
3.	Assembling .....	9
4.	Spare parts list for PAH 10-12.5 / PAHT 10-12.5 .....	15
5.	Spare parts list for PAHT G 10-12.5 .....	16

Introduction

**NOTE: If the pump is disassembled within the warranty period, the pump is no longer covered by the warranty.**

This document covers the instructions for disassembling and assembling the axial piston pumps PAH / PAHT / PAHT G 10-12.5.

Tools provided with tool set 180Z0235:  
• Shaft bush, torpedo  
• Press bush ø18 (Plastic)



1. Disassembling the pump

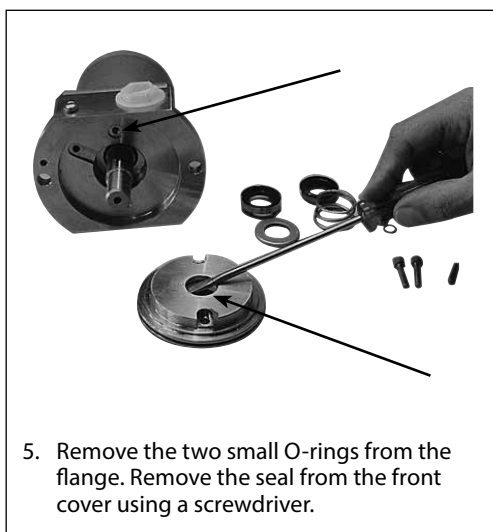
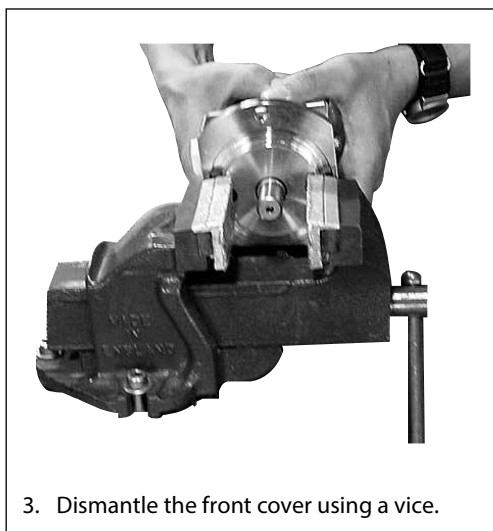
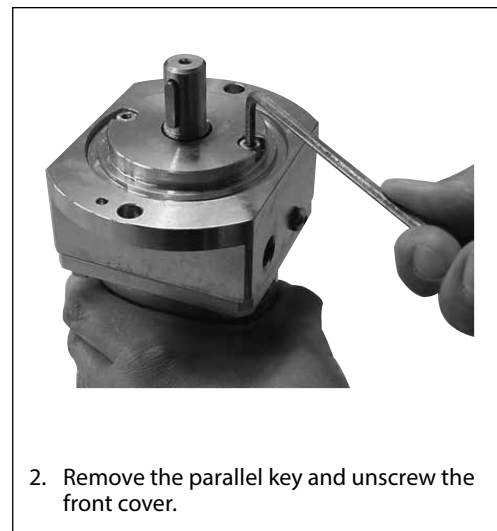

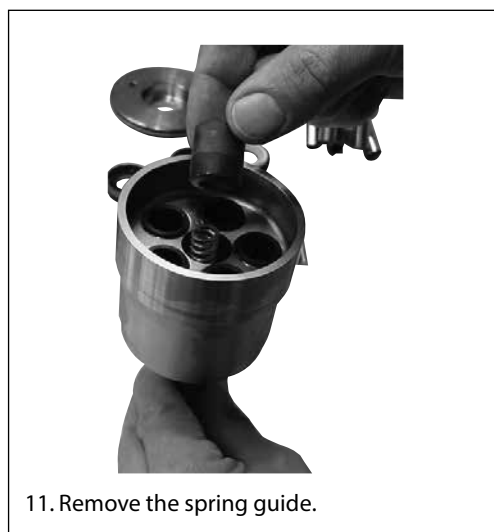
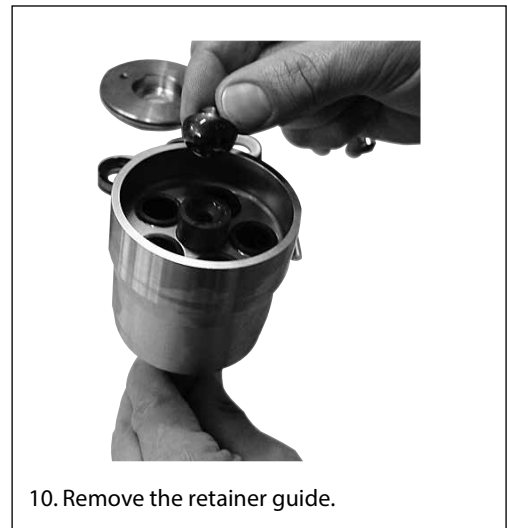
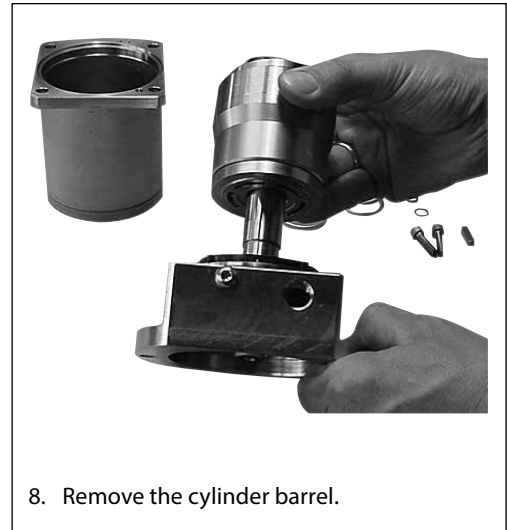



13. Loosen the valve plate using two screwdrivers. Place one of the screwdrivers in the slot of the valve plate.



14. Remove the valve plate.



15. Remove the five O-rings and the five back-up O-rings.



16. Remove the port plate from the flange.

17. Wash all parts and replace all seals (inclusive shaft seal).

18. Inspect all parts carefully (see "Inspection") and replace any worn parts.

19. If the pump has failed, the reason for the failure must be found and fixed before the repaired pump is re-installed.

Instruction

Disassembling and assembling PAH 10-12.5, PAHT 10-12.5 and PAHT G 10-12.5

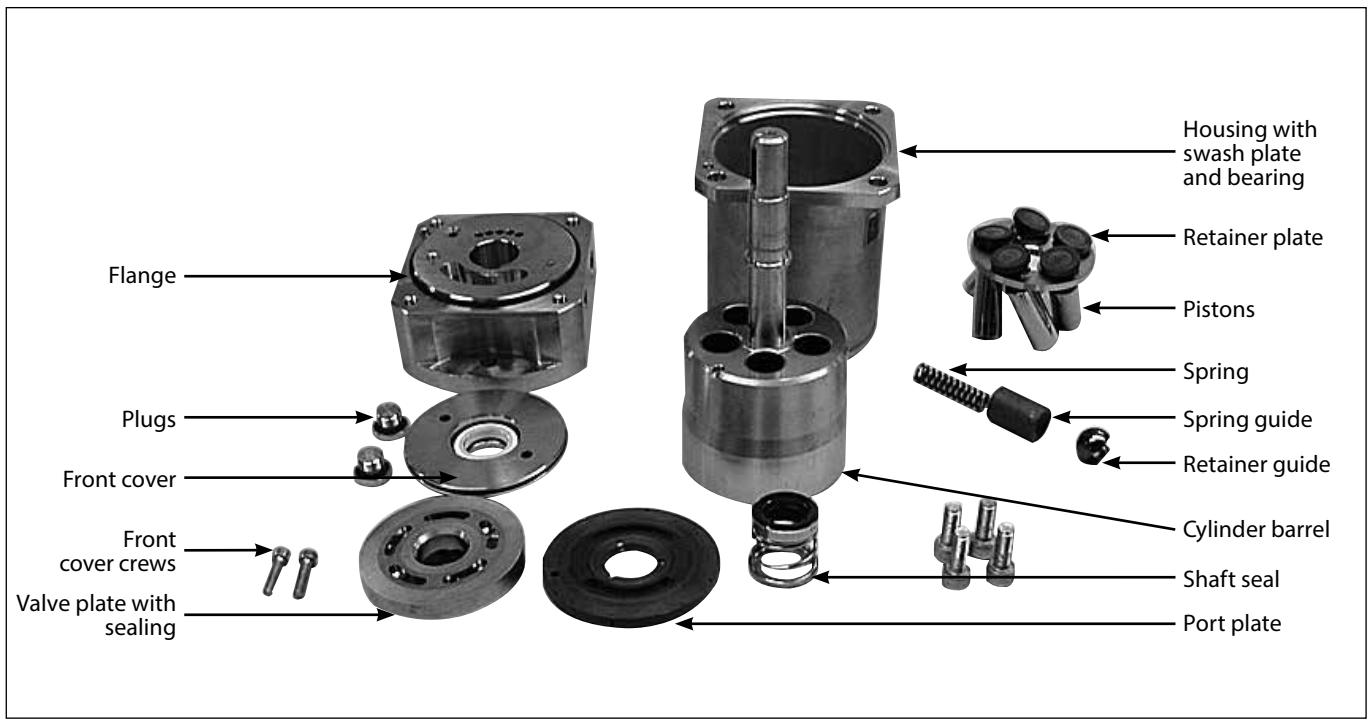

2. Inspection

2.1. Port plate and valve plate

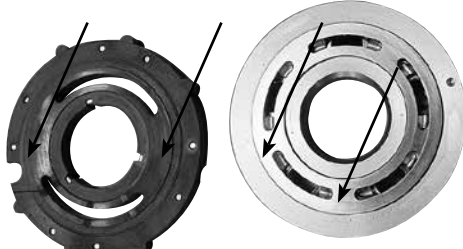

1. Neither port plate nor valve plate must show any sign of wear.



2. Hold a ruler against the surface of the plates and check the tightness against a light source.

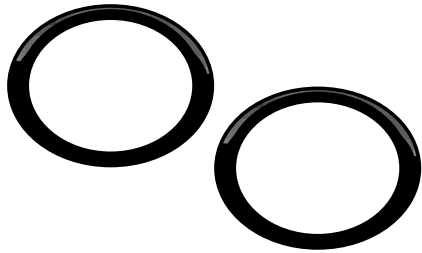

3. Check that both O-rings and back-up rings are not broken and do not show severe wear.

2.2. Pistons



1. The play in the ball and socket joint must not exceed 0.1 mm.  
2. The thickness of the piston shoes must be at least 4.1 mm.



3. Hold a ruler against the surfaces of the piston shoes to check that the surfaces are even and smooth and without any scratches.

### 2.3. Cylinder barrel

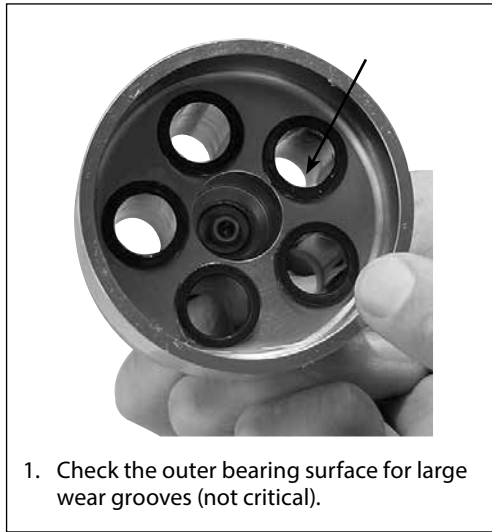

2. Check that the bushings are free from seizure and large scratches.
3. Ensure that the pistons can move freely in the bushings.

### 2.4. Housing

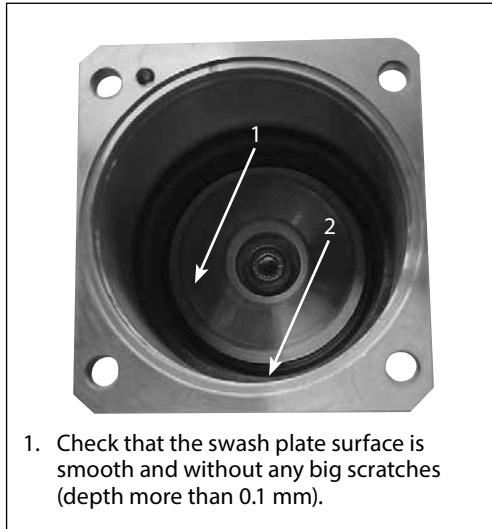

2. Check the bearing (the black part) for large wear grooves (not critical).

### 2.5. Swash plate

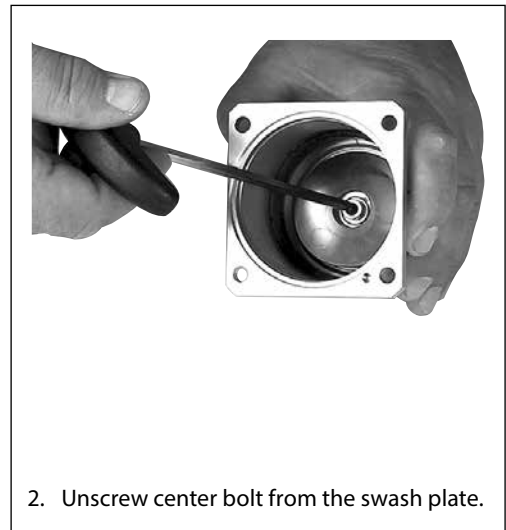
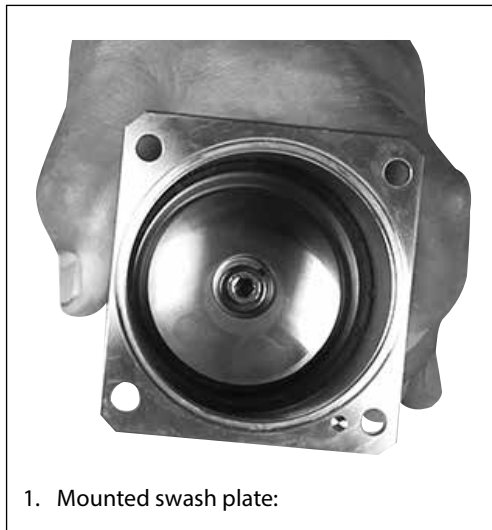



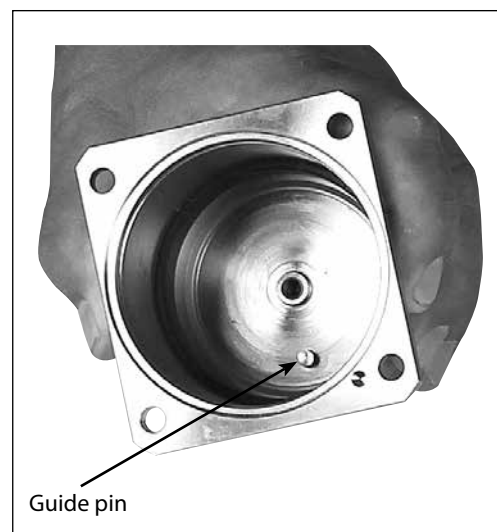
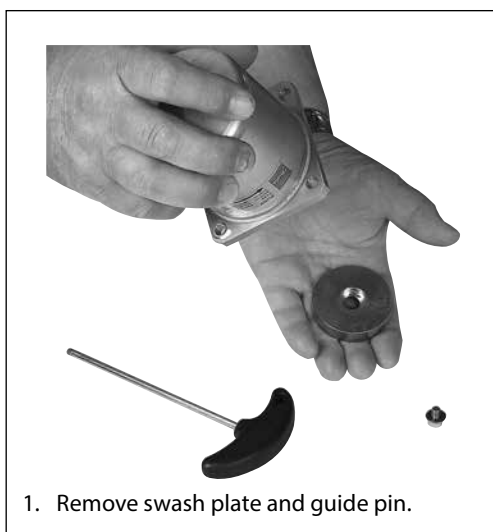

3. Assembling

**WARNING:**  
Do not use silicone when assembling the pump. Do not reuse disassembled O-rings; they might be damaged. Always use new O-rings.

**Important:**  
It is essential that the pump is serviced in conditions of absolute cleanliness. All parts must be absolute clean before mounting.

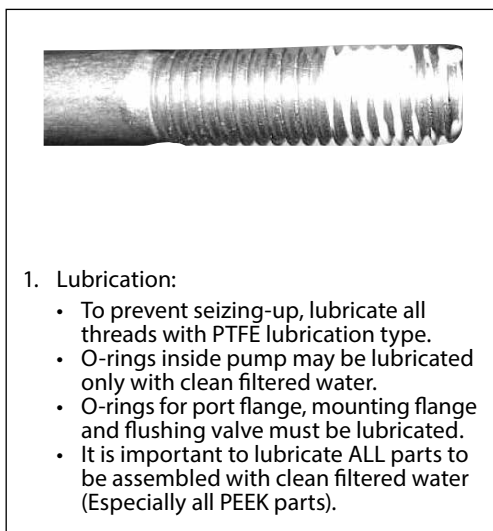

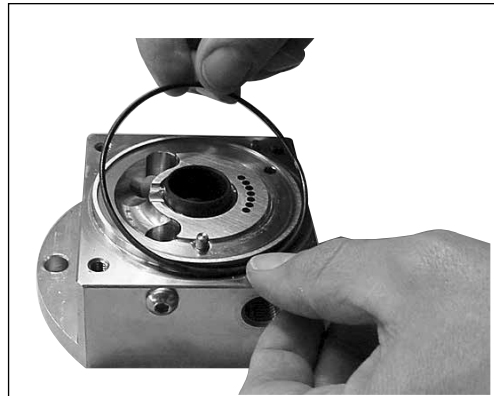

3. Mount the O-ring on the flange.

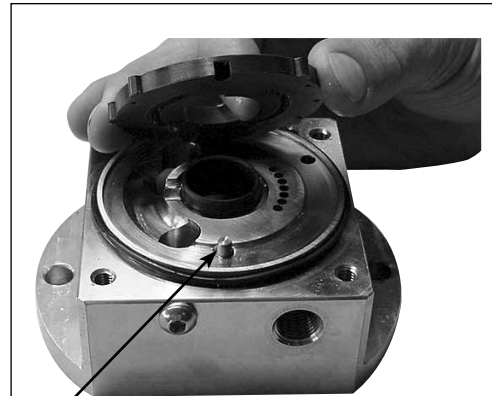

Guide pin

4. Mount the port plate in its right position using the pin as guide.

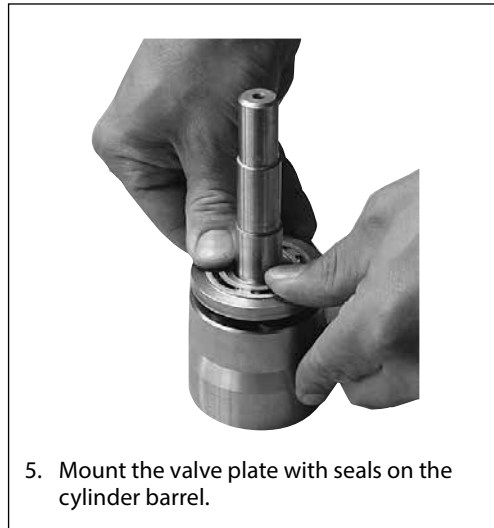

5. Mount the valve plate with seals on the cylinder barrel.

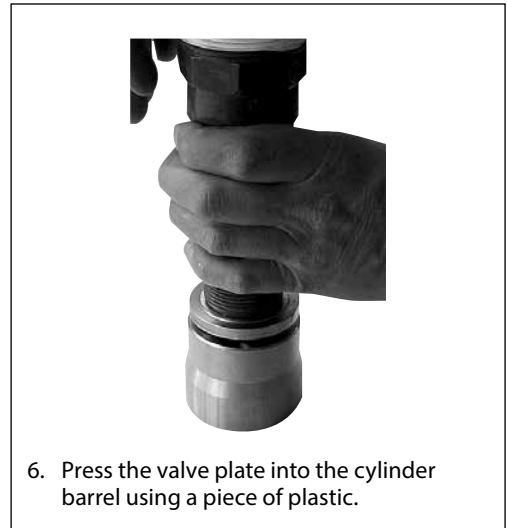

6. Press the valve plate into the cylinder barrel using a piece of plastic.

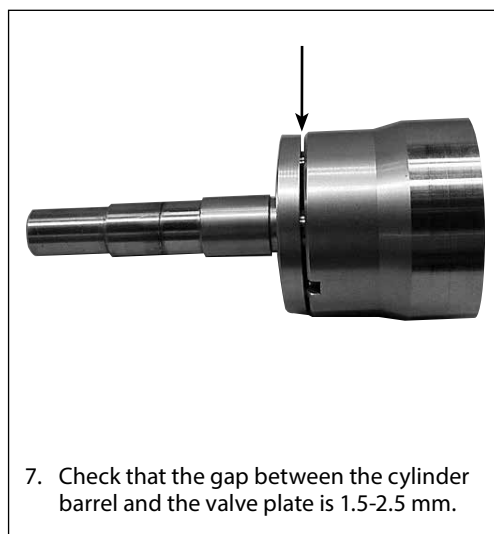

7. Check that the gap between the cylinder barrel and the valve plate is 1.5-2.5 mm.

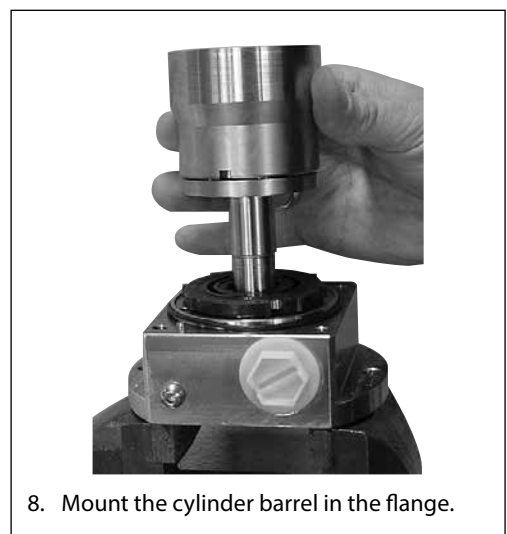

8. Mount the cylinder barrel in the flange.

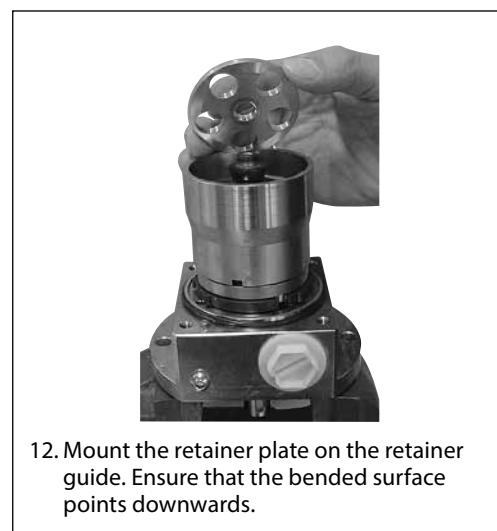

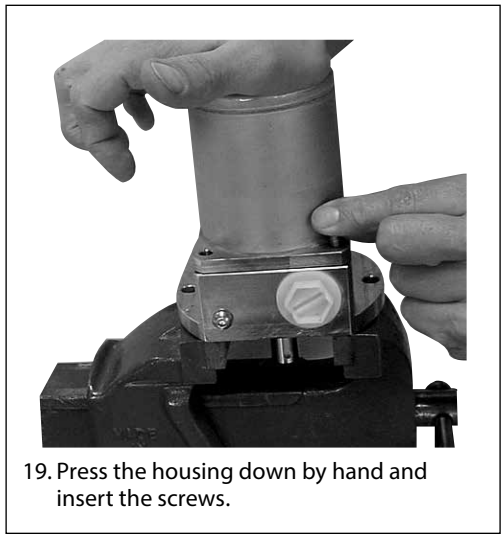
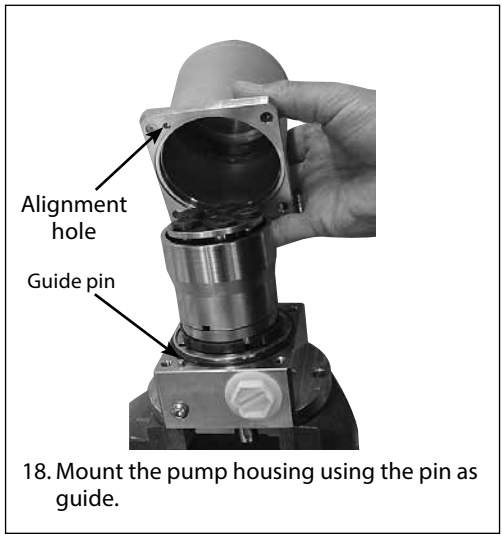
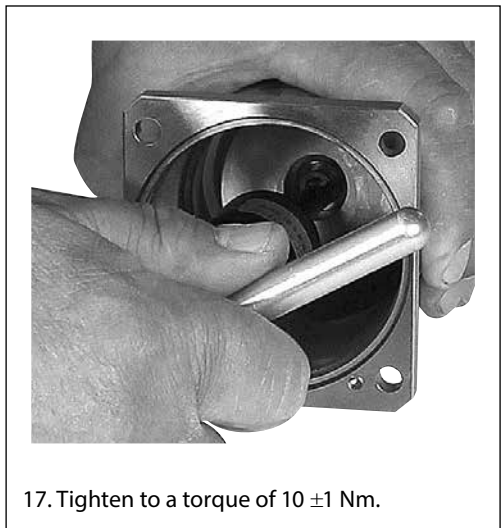
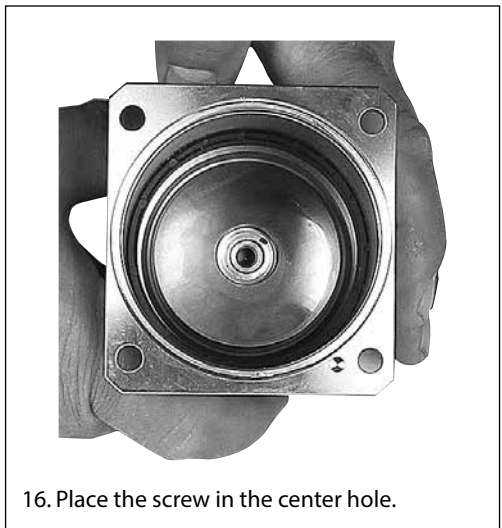
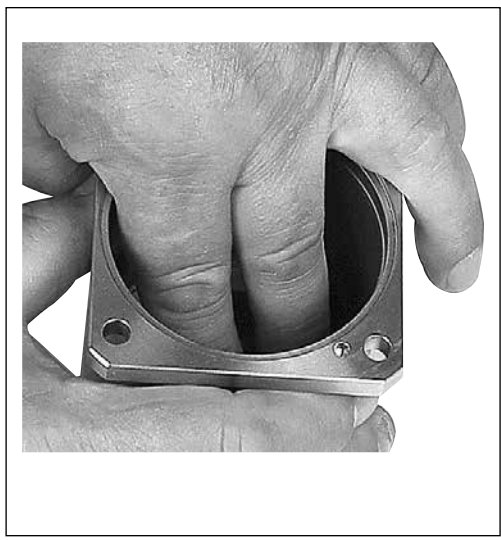
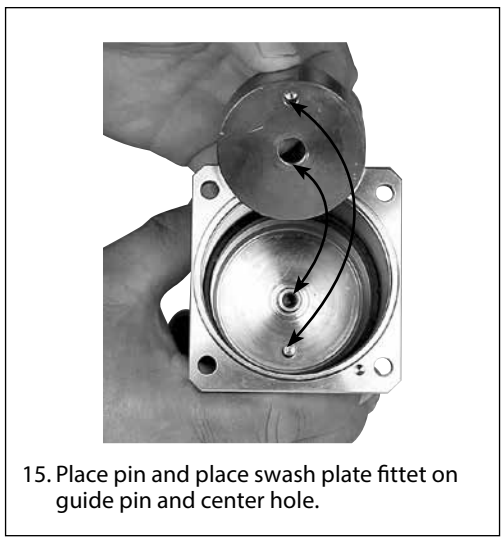

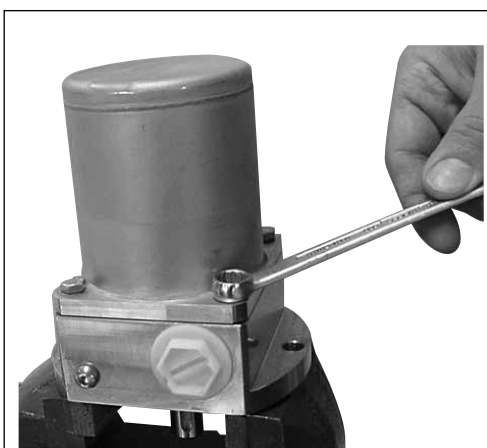

20. Tighten the screws to a torque of 22 Nm.

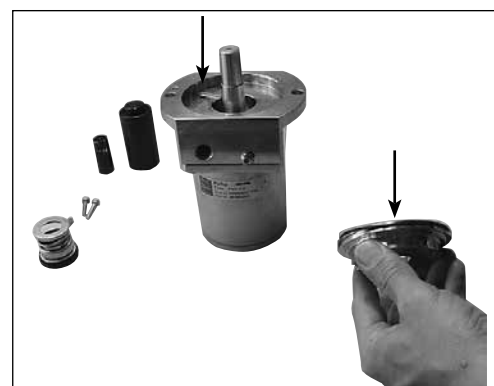

21. Mount the two O-rings in the flange and the O-ring on the front cover.



22. Wet the shaft seal with water and mount it in the front cover. Ensure that it is pressed to the bottom.



23. Mount the washer with the edge pointing upwards.



24. Mount the spring.



25. Fit the hollow bush onto the shaft.

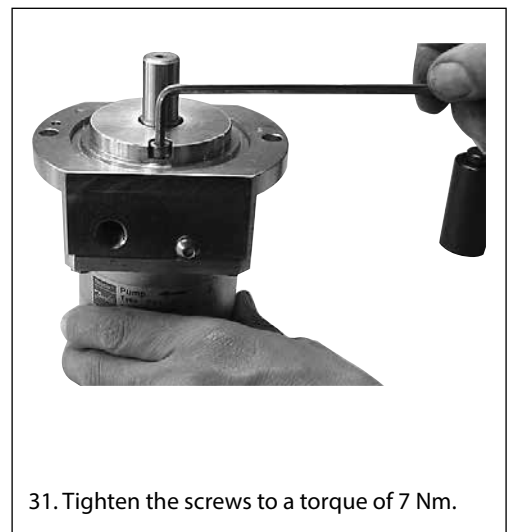



**Instruction**
**Disassembling and assembling PAH 10-12.5, PAHT 10-12.5 and PAHT G 10-12.5**
**4. Spare parts list for  
PAH 10-12.5 / PAHT 10-12.5**

Pos.	Qty.	Designation	Material	180B4105 - Seal set (PAHT 10-12.5)	180B4107 - Cylinder barrel set (PAHT 10-12.5)	180B4113 - Cylinder barrel set (PAH 10-12.5)	180B4108 - Valve plate set (PAHT 10-12.5)	180B4106 - Piston set (PAHT 10-12.5)	180B4114 - Piston set (PAH 10-12.5)	180B4305 - Swash plate set (PAHT 10)	180B4306 - Swash plate set (PAHT 12.5)	180Z0235 - Tool set
-	1	Shaft bush, torpedo	-									X
-	1	Press bush	-									X
1	1	Housing	AISI 304 / PEEK									
2	1	Pin	AISI 316	X								
5	4	Screw	AISI 304	X								
31	1	Swash plate	AISI 431							X	X	
32	1	Screw	AISI 304							X	X	
33	1	Washer	AISI 304							X	X	
34	1	Pin	AISI 316							X	X	
61	1	Cylinder barrel	AISI 431 / PEEK		X	X						
62	1	Spring	AISI 316Ti					X	X			
63	1	Spring guide	PEEK					X	X			
64	1	Retainer ball	PEEK					X	X			
65	1	Retainer plate	AISI 304					X	X			
66	5	Piston	AISI 431/ PEEK					X	X			
67	1	Key	AISI 316Ti	X								
91	1	Port plate	AISI 304 / PEEK				X					
92	1	Valve plate	AISI 431				X					
93	5	Back up ring	PTFE	X			X					
94	5	O-ring	NBR	X			X					
121	1	Port flange	AISI 304 / PEEK									
122	1	O-ring	NBR	X								
123	1	O-ring	NBR	X								
124	1	Shaft seal	AISI 304 / NBR	X								
125	1	End cover	AISI 304									
126	1	Pin	AISI 316									
127	2	Screw	AISI 304	X								
130	2	O-ring	NBR	X								
135	1	Pin	AISI 316				X					
136	2	O-ring	NBR	X								
-	1	Service instruction (180R9095)	-	X	X	X	X	X	X	X	X	

**Instruction**
**Disassembling and assembling PAH 10-12.5, PAHT 10-12.5 and PAHT G 10-12.5**
**5. Spare parts list for PAHT G 10-12.5**

Pos.	Qty.	Designation	Material	180B4312 - Seal set (PAHT G 10-12.5)	180B4315 - Cylinder barrel set (PAHT G 10-12.5)	180B4313 - Valve plate set (PAHT G 10-12.5)	180B4314 - Piston set (PAHT G 10-12.5)	180B4321 - Swash plate set (PAHT G 10)	180B4322 - Swash plate set (PAHT G 12.5)	180Z0235 - Tool set
-	1	Shaft bush, torpedo	-							X
-	1	Press bush	-							X
1	1	Housing	AISI 304 / PEEK							
2	1	Pin	AISI 316	X						
5	4	Screw	AISI 304	X						
31	1	Swash plate	AISI 431					X	X	
32	1	Screw	AISI 304					X	X	
33	1	Washer	AISI 304					X	X	
34	1	Pin	AISI 316					X	X	
61	1	Cylinder barrel	AISI 431 / PEEK		X					
62	1	Spring	AISI 316Ti				X			
63	1	Spring guide	PEEK				X			
64	1	Retainer ball	PEEK				X			
65	1	Retainer plate	AISI 304				X			
66	5	Piston	AISI 431/ PEEK				X			
67	1	Key	AISI 316Ti	X						
91	1	Port plate	AISI 304 / PEEK			X				
92	1	Valve plate	AISI 431			X				
93	5	Back up ring	PTFE	X		X				
94	5	O-ring	NBR	X		X				
121	1	Port flange	AISI 304 / PEEK							
122	1	O-ring	NBR	X						
123	1	O-ring	NBR	X						
124	1	Shaft seal	AISI 304 / NBR	X						
125	1	End cover	AISI 304							
126	1	Pin	AISI 316							
127	2	Screw	AISI 304	X						
130	2	O-ring	NBR			X				
135	1	Pin	AISI 316	X						
136	2	O-ring	NBR	X						
-	1	Service instruction (180R9095)	-	X	X	X	X	X	X	





**Danfoss A/S**  
High Pressure Pumps  
Nordborgvej 81  
DK-6430 Nordborg  
Denmark